

AP-42P

1/4 Ton Arbor Press
Versatile, light-duty press.
Single-acting, spring return.

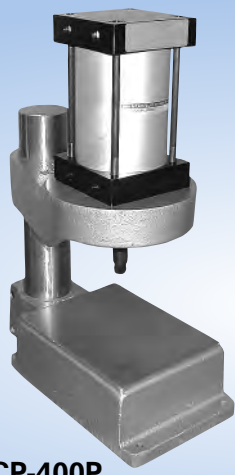

CP-400P

3/4 Ton Column Press
Column provides infinitely variable daylight settings and permits radial swing.



AP-400P

3/4 Ton Arbor Press
Heavy-duty cast iron frame is extremely rigid.



AP-600P

1 3/4 Ton Arbor Press
Welded steel plate frame. Cylinder mount and table are milled to provide precise rod alignment.

Air Presses Automate Tasks

Economical air powered presses reduce production costs by automating crimping, heat sealing, bending, forming, pressing, swaging, riveting and burnishing operations. Easy hook-up. Just attach to your shop air supply. No wiring, pumps, or motors needed.

Single-Acting Air Presses

Besides the AP-42P shown on this page, Mead offers two other single-acting alternatives. AP-122 combines a 4" bore single-acting cylinder (H-122) with the AP-400M press stand. AP-283 combines a 6" bore cylinder (#6030403) with the AP-600M press stand. A PL-600 cylinder-to-stand adapter plate is required for mounting this cylinder on the stand. Full dimensional drawings are given on the following page.

Press Options

Rod Speed Reduction



To control the downward speed of double-acting presses, place a Mead Dyla-Trol valve (see page 62) in the bottom cylinder port so that incoming air flows freely and exhausting air is metered. Model MF1-25 is suitable for the control of all presses under most conditions.

Two Hand Control Unit

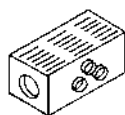

Models with a "C" suffix are supplied with a two hand anti-tiedown unit. Recessed trigger buttons, located in each end of the compact unit, require the press operator to use both hands concurrently to operate the press. Models CP-400C and AP-400C include the CSV-102, which has a built-in power valve. Model AP-600C includes the CSV-101 and a 1/2" power valve (C5-3). All air logic. No electrical wiring. See page 63 for the two hand controls. See pages (22-23) for the power valve.

	1/4 Ton Arbor Press	3/4 Ton Column Press	3/4 Ton Arbor Press	1 3/4 Ton Arbor Press
Press Stand Only	AP-42M	CP-400M	AP-400M	AP-600M
Cylinder Mounted On Stand**	AP-42P	CP-400P	AP-400P	AP-600P
Complete Press with Two Hand Controls (Not Piped)	-	CP-400C	AP-400C	AP-600C
Double Rod Option (DR)	NA	●	●	●
Non-Rotating Option (NR)	NA	●	●	●
Specifications				
Cylinder Bore (In.)	2 1/4	4	4	6
Thrust at 100 PSI (lbs.)	477	1508	1508	3393
Standard Stroke Length (In.)	2 (Spr. Ret)	4*	2 1/2*	4*
Table Width and Depth (In.)	3 x 3	6 7/8 x 8 3/4	5 x 5	8 x 8

Note: Standard column for Column Press is 14" long. Longer column (18" max.) is available on request.

* Additional stroke available to 4" on AP-400 and to 6" on AP-600. Consult factory.

** Consult website for press hookups.

Double Rod Option (DR)



Double-acting press cylinders may be ordered with the piston rod extending from both ends. This minimizes rod deflection and make it possible to adjust stroke length. When a CP-400 is ordered with double rod, spacers are supplied to facilitate adjustment.

Press Speed Boost

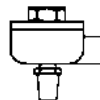

Quick exhaust valves increase rod speed by allowing exhaust air to be dumped right at the cylinder instead of passing back through the directional valve. If speed is to be increased in both directions on double-acting presses, use one QEV in each port. Use model QEV-3 with 1/4 ton presses and model QEV-2B on 3/4 and 1 3/4 ton models. See page 69 for more information regarding QEVs.

HP-600P

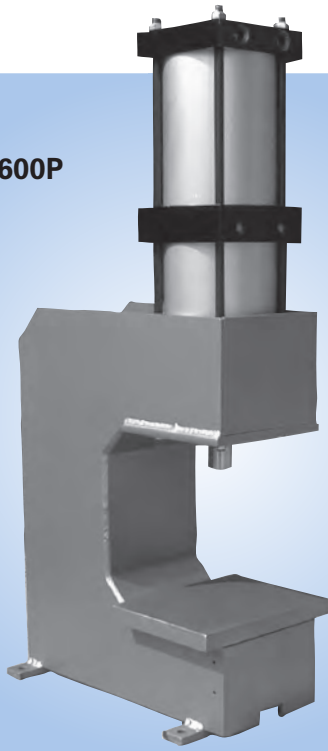

Mead's latest press utilizes multiple stages to achieve a dramatically increased output force. A standard shop air input (110 PSI) can achieve a push output force of up to 6057 lbs. The standard model has two stages, but upon request Mead can provide more stages which means higher output force at an even lower input force.

Economical air powered presses reduce production costs by automating crimping, heat sealing, bending, forming, pressing, swaging, riveting and burnishing operations. Easy hook-up. Just attach to your shop air supply. No wiring, pumps, or motors needed.

Operating Specifications

Temperature Range: -40°F to +250°F (to +400°F on request)

Lubrication: For maximum cylinder life, non-detergent petroleum based oil is recommended. Non-lube seals available.

Filtration: Standard 40 micron filter for maximum life.

Maximum Pressure: 110psi

Maximum Output Force: 6057lbs

Thrust Multiplier: 55*

*To determine thrust at other inlet pressure, multiply factor by desired pressure

Materials

Rod Bearing: Teflon-impregnated, hardcoated aluminum

Heads: Machined from solid aluminum bar; black anodized

Tubes: Aluminum hard anodized to 60 Rc

Piston: Solid high alloy aluminum

Piston Rod: High tensile ground and polished hard chrome plated steel

Piston and Rod Seals: Wear compensating Buna N vee rings. Self-lubricating seals also available (see Option NL).

Tube Seals: Buna N O-rings

Rod Wiper: Dupont Teflon®

Tie Rods: High tensile steel torqued to allow for flexure.

Stand: Welded steel frame.

Weight: 250 lbs.

Dimensions

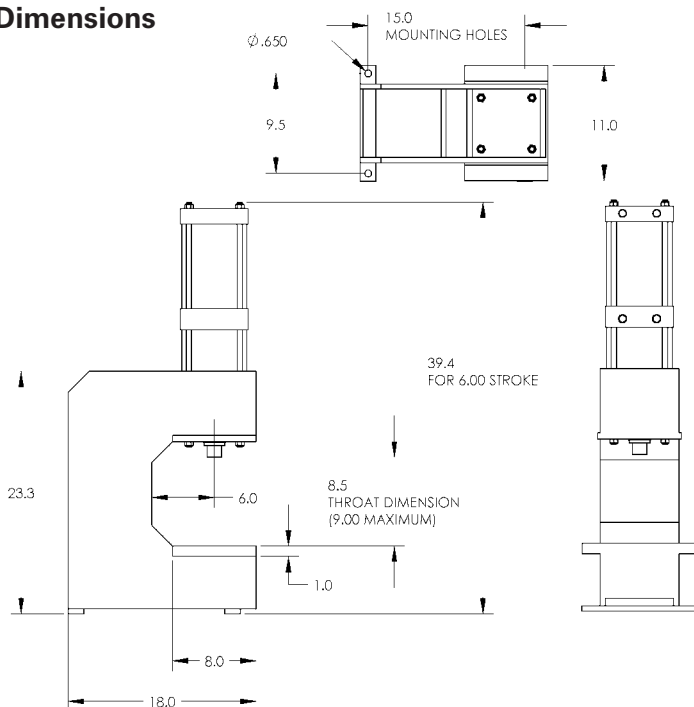

Note: For each inch of stroke overall height increases by 2"

Ordering Information

Model #	Description
HP-600M	Press stand only.
HP-600P	Cylinder mounted on stand
HP-600C	Complete press with 2 hand controls (not piped).

Specify:

Throat dimension "T" Min=1/2" Max=9"

Stroke dimension "S" Min=1/4" Max=9"

Sample Part

HP-600P G2 - T8.00 - S4.00



Contact Mead to consult for more than the standard two stages.

NOTE: Stroke cannot exceed throat.

Available Cylinder Options:

- CR = Cushion Rear
- IPR = Inter-Pilot Rear
- MP = Magnetic Piston

Consult Factory for Other Options
Consult Website for Press Hook-ups

AP-42

Shipping Weight: Stand Only = 9 lbs.
Stand/Cyl. = 10 lbs.

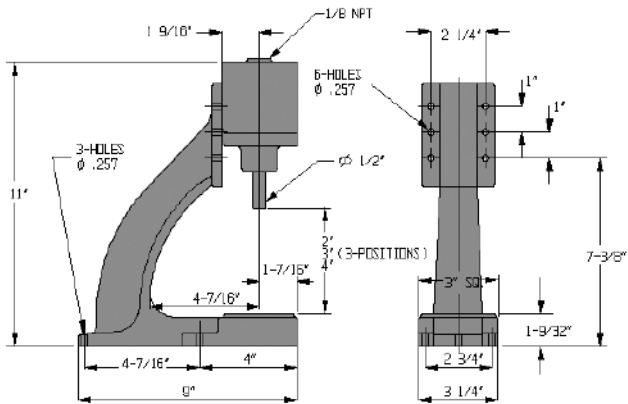

This press combines the AP-42M press stand with a Mead H-42 single-acting cylinder (2 1/4" bore, 2" stroke). Cylinder details are on page 54.

AP-122

Shipping Weight: Stand Only = 45 lbs.
Stand/Cyl. = 52 lbs.

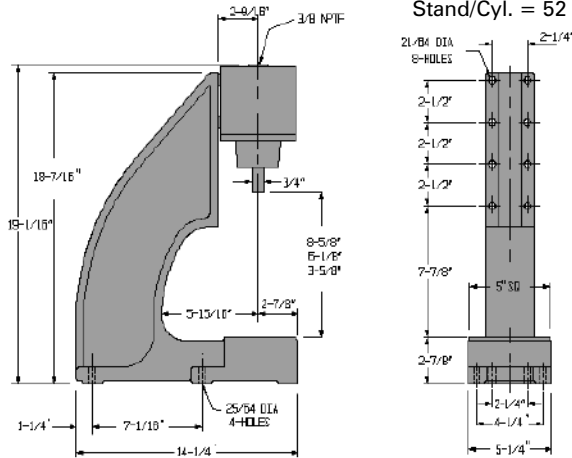

This press combines the AP-400M press stand with a Mead H-122 single-acting cylinder (4" bore, 2 5/8" stroke). Cylinder details are on page 54.

AP-400

Shipping Weight: Stand Only = 45 lbs.
Stand/Cyl. = 52 lbs.

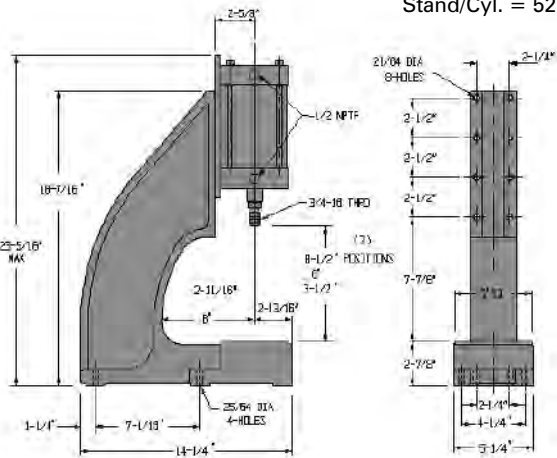

For non-standard double-acting service with strokes up to 4", use pages 36-37 to create a 4" bore cylinder for use with this stand. The PL-400 cylinder-to-stand adapter plate will be required.

CP-400

Shipping Weight: Stand Only = 90 lbs.
Stand/Cyl. = 105 lbs.

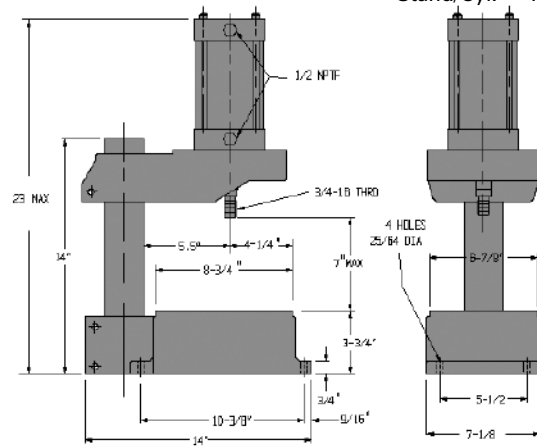

For other stroke lengths, heavy-duty or other options, use pgs. 36-37 to create any 4" bore cylinder for use with this press stand.

AP-283

Shipping Weight: Stand Only = 85 lbs.
Stand/Cyl. = 125 lbs.

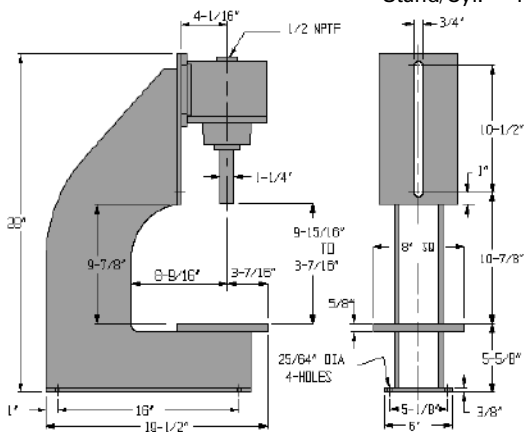

This press combines the AP-600M stand with Mead's #6040303 (H-283 with 3" longer ram, p. 54) single-acting cylinder (6" bore, 3" stroke). A PL-600 cylinder-to-stand adapter plate is required to mount this cylinder.

AP-600

Shipping Weight: Stand Only = 85 lbs.
Stand/Cyl. = 120 lbs.

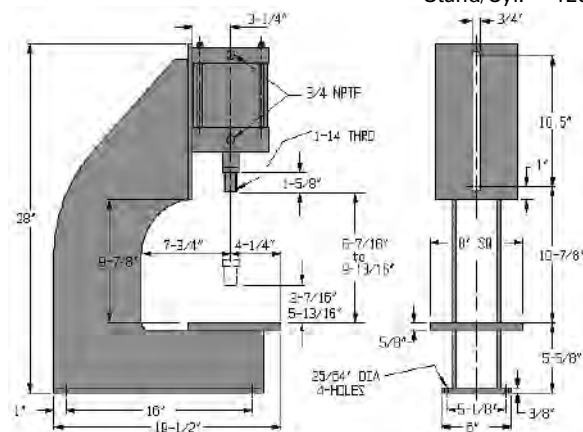

For non-standard double-acting service with strokes up to 6", use pages 36-37 to design a 6" bore cylinder for use with this stand.